

GARDIX Safety Inductive Sensors GX-IS-K.40-AP(-IB)

Applicable as Muting Sensors at Safety Systems GARDIX GX-M and GX-S

Operating Manual and Control Drawing No. OM-IS-01b



II 2 G EEx ib IIC T6

- Safety level 4 at EN 954, BG-PRÜFZERT
- Type of Ex protection "intrinsically safe" 2 II G EEx ib IIC T6
- Types GX-IS-K.40AP-IB, applicable in Ex Zones 1 and 2
- ATEX-Certification: TÜV 97 ATEX 1154
- For embeddable or not embeddable installation methods

Technical Data	Type	GX-IS-KN40AP-IB	GX-IS-KB40AP-IB	GX-IS-KN40AP	GX-IS-KB40AP
Safety level at EN 954		4, when connected at GARDIX systems GX-M or GX-S			
Type of Ex protection at 94/9/EC		II 2 G EEx ib IIC T6		None	
Applicable in Ex zones		Zone 1 and 2		--	
Housing material		Polycarbonate PC, min 10% GF			
Installation		not embeddable	embeddable	not embeddable	embeddable
Rated operating distance s_n		40mm (on steel 37, 120 x 120 x 1mm) (EN60947-2-5)			
Assured operating distance s_a		5mm ... 38mm	5mm ... 32mm	5mm ... 38mm	5mm ... 32mm
Hysteresis		1-4mm			
Safe switched OFF distance ($s_n \times 3$)		120mm			
Protection degree		IP65 at EN 60529			
Supply voltage		12VDC, intrinsically safe		12VDC +-20%	
Maximum supply voltage U_i		13.6VDC		--	
Current consumption		20mA			
Maximum input current I_i		120mA		--	
Maximum power dissipation		280mW		290mW	
Maximum input power P_i		800mW		--	
Internal capacitance / inductance		$L_i = 0 / C_i = 0$		--	
Response time		20ms			
Output		1x PNP (dual redundant) / short circuit protected			
Ambient temperature T_A		$-20^\circ\text{C} < T_A < +60^\circ\text{C}$			
Connection cable		3x AWG24(0,2mm ²) + Shield / L=5m, Ex devices: blue coated			
Socket, optional for types GX-..- S99		Socket M12, Lumberg RSF4, 4 terminals			
Function and LED indication		 Object detected, LED green		 No object detected, LED red	
Output with dynamic test function		PNP-Output: Switched ON to +12VDC Output black - blue		PNP-Output: Open Output black - blue Safe Status	

Installation:

IS2-KN-40-AP-.. (for not embeddable installation):

Sensors for not embeddable mounting arrangement have the highest operating distance, but a part of the parasitic lateral electromagnetic field can disturb the safe function. Lateral protection plates or other metallic objects must not influence the Sensor. For safe function a lateral free space around the sensor must be guaranteed. Lateral protection plates must not rise above the sensor. The minimal distances A for different materials is:

Steel 37: 40mm	Stainless Steel: 35mm	Copper: 20mm
Aluminum foil: 40mm	Aluminum: 20mm	Synthetics: 0mm

GX-IS-KB40 (for embeddable installation):

For embeddable mounting sensors no lateral free space is required (A=0). It's possible to realize a better mechanical protection and they have a higher immunity against spurious releasing. In a not embedded mounting arrangement the sensors reach a lower level of operating distance (s_a) than sensors for not embeddable mounting.

Sensor for free mounting condition

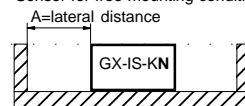

Sensor for flush mounting condition A=0mm



Dimensions:

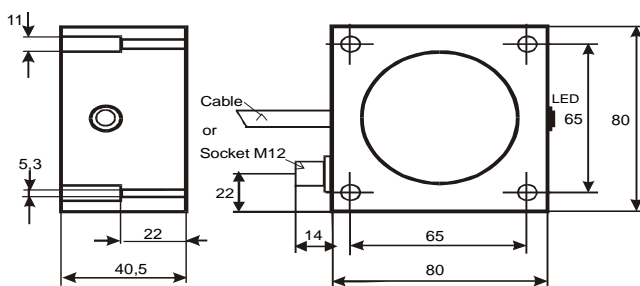

Connection layout: (Types GX-IS-...-S99)

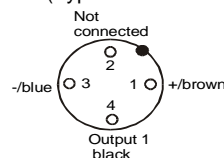

Control Drawing for Hazardous Areas:

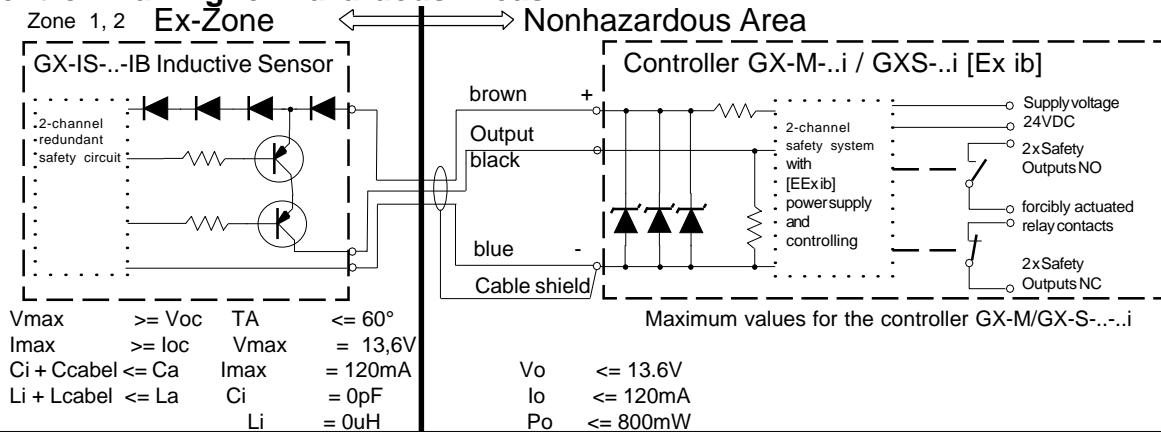

Operating manual, short form / CE Declaration of conformity:

When installing and operating the sensor, it is necessary to take into consideration the complete operating manual for the safety systems GX-M or GX-S. The safety inductive sensors GX-IS-K.40-AP are only approved when operated at a safety system GX-M or GX-S. For stand alone safety applications use safety inductive sensors series IS2-.. or ISx-10-B, also applicable for Ex zones 1, 2, 21, 22.

Installation prescriptions for Ex hazardous locations:

It is necessary to take into consideration the valid international and national rules and regulations (En 60079-14). Do not exceed the maximum ratings. To connect cables inside hazardous locations only use certificated Ex e housings. All cable terminals must be connected outside hazardous locations. Do not open or close the connector when the supply voltage is connected to the cable. When installing the sensor, the safety lock device must be fitted at the cable connector. The additional adhesive warning label must be fixed to the connector housing at the connection cable. Only connectors, Binder series 713, 4 terminals, or Lumberg RKTs/RKTW 4, are allowed. It is necessary to take into consideration the mounting prescription of the connector manufacturer.

The safety inductive sensor GX-IS-K.40AP-IB is only applicable in Ex zones 1 and 2 and must be connected at a GARDIX safety system GX-M or GX-S. The capacitance and inductance of the connection cable must be taken into account.

Mounting description

For not embeddable mounting sensors the minimal lateral space around the sensor must keep free. All types of sensors can be mounted on a metallic ground-plate. Metallic protection plates must not rise above the sensor. Electrolytic fluids, graphitized greases or other magnetizable substances can disturb the correct function. Sensors for embeddable installation reach the nominal operating distance only in a metallic embedded mounting. The electrical connections must be exactly as shown in the control drawing for hazardous areas. In order to guarantee safety of a work installation, when connected at a safety system GX-M or GX-S. Cable shields should be correctly connected to PE or Minus. The connection cable must not be installed parallel to high voltage cables. The sensor can not be driven with unloaded outputs.

Function

When a metallic object is entering the detection field, the dynamic tested output becomes active (switching ON). Is no object detected the output becomes inactive (switching OFF). The proofed sensors of the series GX-IS-..AP-.. (AP=Accident Protection) are built in a 2-channel different redundancy. Failures and disturbances of any kind, result in the output switching OFF and the LED blinking red.

The faulty state is the same as no object is detected. (Output IS switching OFF - Safety State)

The emergency OFF state is only resetable by the safety controller GX-M or GX-S.

Maintenance

The sensor does not require any special maintenance. Magnetic precipitations must be cleared. Equipment must only be repaired or serviced by the manufacturer.

General notes to the operating distance

The nominal operating distance s_n (EN60947-2-5) does not take into account production tolerances and influences of temperature or voltage. The safe operating distance s_a is the minimal reachable operating distance on steel 37 (120mmx120mmx1mm) on all mounting arrangements. On other materials or smaller objects a reduction factor must be taken into account.

Material	Reduction factor
Steel 37	1
Stainless steel	0.8
Aluminum	0.4

Safety distance s_d : An inductive sensor is safe switched OFF, when the distance between sensor and actuator plate is greater then $3 \times$ nominal distance s_n .

We reserve the right to modify our equipment. Our equipment is designed such way, that it has the least possible adverse effect on the environment. It neither emit or contain any damaging substances and use a minimum of energy and resources. No longer usable or irreparable units must be disposed of in accordance with local waste disposal regulations.

Safety instructions

When installing and operating with the sensor, it is necessary to take into consideration the relevant international and other national regulations.

ATEX 118a, ElexV, TRbF, TRD, UVV, EX-RL(BGR 104), BetrSichV(ATEX 137), single directive 1999/92/EG.

Standards met:

- EN 50014, EN 50020; EN 61496-1; prEN 61496-2; EN 954

EN 61000-6-1/-2, EN 61000-6-3/4, EN 60529

- Ex protection: 94/9/EG (ATEX 100a)

- Machine directive: 98/37EG

- Low voltage directive: 73/23/EWG, 93/68/EWG

- EMC: 89/336/EWG, 91/263/EWG, 92/31/EWG, 93/68/EWG

Approvals

BG-PRÜFZERT, certification No.: 99117/99118,

TÜV 97 ATEX 1154/N1/N2

General notes

We reserve the right to modify our equipment. Our equipment is designed such way, that it has the least possible adverse effect on the environment. It neither emit or contain any damaging substances and use a minimum of energy and resources. No longer usable or irreparable units must be disposed of in accordance with local waste disposal regulations.

Declaration of Conformity

The conformity of the devices with the EC standards and directives and the EC-type examination certificate and the observation of the Quality Safety System ISO 9001 with the ATEX module "Production", declares:

Hans Bracher, Matrix Elektronik AG

GX-IS_e3/DEC.20.05/HB