

Optical Rotation Speed Counter Type OCS-LTD S150

- For dynamic rotation speed control up to 100'000 RPM
- Simple connection of synthetic fibre optics (POF) without special tools
- Visible laser emitter, red 650nm



Technical Data	Type	OCS-LTD S150
Laser class		Class 2, 650nm, visible red, <1mW
Rotation speed detection range		300 RPM up to 100'000 RPM (at 2 partition reflector-disc) ^{Note1}
Frequency		0.01kHz - 5kHz
Output rise and fall time		≤ 1us
Supply voltage		24 VDC +- 10%
Absolute maximum supply voltage Um		Um = 30VDC
Maximum current consumption		70mA
Maximum power dissipation		ca. 1.85W
Output 1		1 x Push-Pull, short circuit protected, max. 20mA
Output 2		1 x NPN, short circuit protected, max. 20mA
Output impedance		max.150Ω
Ambient light influence		The sensitive area of the POF must be protected against ambient light
Housing		Synthetic (Polycarbonate, Polystyrene)
Mounting		On DIN rail at EN 50022 or with 2 screws
Ambient operating temperature TA		-20°C < TA < +50°C
Electrical connection		Terminal screws
POF connection		Screw adaptation, thread 1/4-36UNS-2B
POF length		Dependent on type and structure of the used POF
Applicable POF's		Outside diameter: 2.2mm / Core diameter: 1mm
Accessories (not included)		- POF Quick-connector, Phoenix, type Q-FSMA-KT
Options		--

Output / Function:

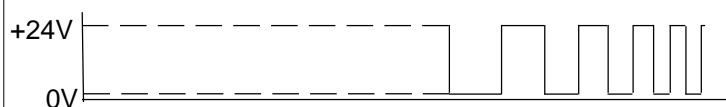
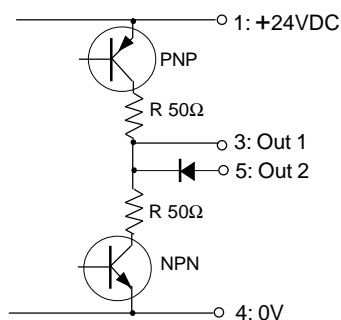

 Rotary indicator is static:
Output: Holds "H" or "L"

 Rotary indicator is turning:
Output generates pulses equal to the rotation speed.

Note 1:

The real reachable switching/rotary frequency is dependent on the condition of the marking disc and the careful working up of the optical fibres. The maximum rotation speed detection range will be reduced by applications with reflection-disc with more than 2 partitions.

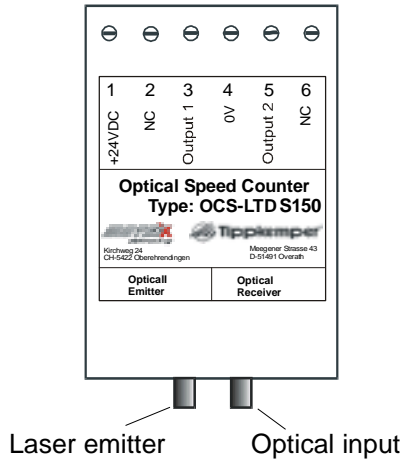
Connection: OCS-LTD S150:



- | | |
|---|-------------------|
| 1 | +24VDC |
| 2 | NC |
| 3 | OUT 1 (Push-Pull) |
| 4 | OV |
| 5 | OUT 2 (NPN) |
| 6 | OV |

Dimensions:

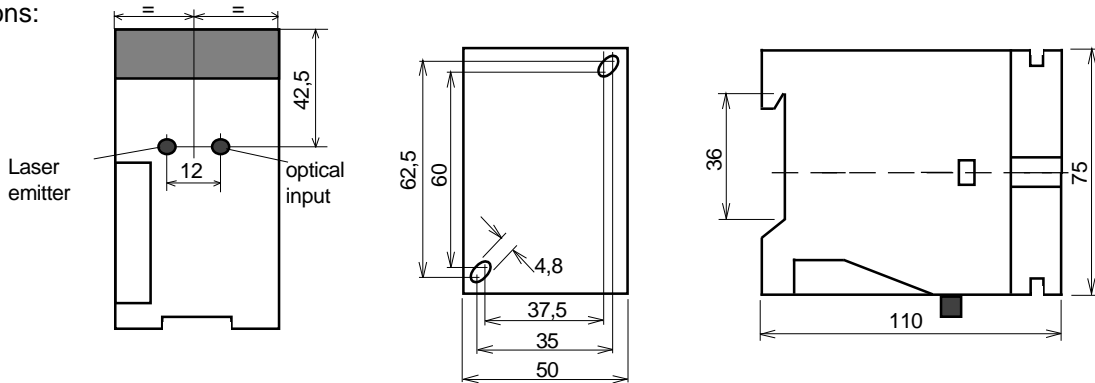

Operating Manual / EC - Declaration of Conformity:

General mounting prescriptions:

Do not exceed the maximum ratings. The electrical connections must be exactly as shown in the connection diagram. For highest noise immunity use twisted pair cables with shielding. The cable shield should be connected to the protection earth, large-surfaced. Connection cables must not be installed parallel to high voltage cables.

Function:

The sensor can only be used with connected fibre optics. Laser light reflection alterations, generated by the marking disc of the spraying apparatus, will be amplified and formed.

Using the fibre optics:

The fibre optics (POF) must be assembled, mounted and cutted careful. Use special cutting tools for cutting into lengths. The face of optical fibers must be completely even and free of scratches. The applicable length of the POF is dependent of there type and structure. The functional safety of the sensor is given by the condition of the marking disc and the careful working up off optical fibres. The fibre optics must not be buckled or to tight laid. Tight laying or buckling decrease the function safety.

Maintenance

Protect the fibre optic adaptor of the sensor and the optical fibres against pollution. Please set up the protection caps if no optical fibres are connected. If the fibre optic adapter is contaminated, clean with alcohol. Do not use aggressive solvents. Plastic optical fibres can be destroyed by strong solvents. Equipment must only be repaired or serviced by the manufacturer.

General Safety Informations

The sensor OCS-LTD S150 must not be used for Accident-Prevention! In worst case of disturbance, the outputs can show any state. When installing and operating with the sensor, it is necessary to take into consideration the relevant international and other national regulations.

Standards met:

EN 60825-1:2007 EN 60825-2+A1:2007;
 EN 60529:2000; EN 60950-1:2006; EN 61000-2-4:2002,
 EN 61000-4-1:2000, EN 61000-4-4:2001,
 EN 61000-4-5:2001, EN 61000-4-11:2001,
 EN 61000-6-1:2001, EN 61000-6-2:2001,
 EN 61000-6-3:2001/A11:2004, EN 61000-6-4:2001,
 Machine directive: 2006/42/EC
 EMC: 2004/108/EG
 RoHS: 2002/95/EG

General Notes

We reserve the right to modify our equipment. Our equipment is designed such way, that it has the least possible adverse effect on the environment. It neither emit or contain any damaging or siliconized substances and use a minimum of energy and resources. No longer usable or irreparable units must be disposed of in accordance with local waste disposal regulations.

Declaration of Conformity:

The conformity of the devices with the EC standards and directives and the observation of the Quality Safety System ISO 900:2000 with the ATEX module "Production", declares:

Hans Bracher, Matrix Elektronik AG

Tippkemper - Matrix GmbH
 Meegener Str. 43 D-51491 Overath
 Tel.: +49 2206 9566-0 Fax -19
 info@tippkemper-matrix.com

Matrix Elektronik AG (Manufacturer)
 Kirchweg 24 CH-5420 Ehrendingen
 Tel.: +41 56 20400-20 Fax -29
 info@matrix-elektronik.com