

Operating manual: LTG-BCC-1CA-TF Laser distance sensor



SEV 23 ATEX 0648 X

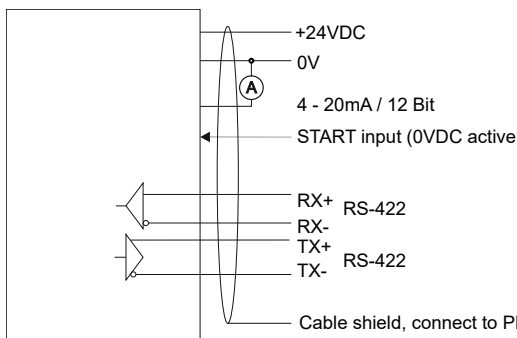

 Ex db [op is Ga] IIC T4 Gb
Ex tb [op is Da] IIIC T135°C Db

- Precise distance measurement with a reproducibility of < 2,5µm
- High measuring rate up to 2 kHz
- Measurement range 25mm, 18mm < x < 43mm
- Stable measured values regardless of the color and brightness of the measurement object
- Analogue output signal 4 - 20mA and data interface RS422
- Easy alignment thanks to visible laser light
- Aluminum housing

Technical Data	Type	LTG-BCC-1CA-TF
Gas Ex protection designation		II 2(1)G Ex db [op is Ga] IIC T4 Gb
Dust Ex protection designation		II 2(1)D Ex tb [op is Da] IIIC T135°C Db
For use in Ex Zones		Zones (0), 1, (20), 21
Measurement methods		Optical triangulation
Light Source		Class 2 laser according to EN 60825-1:2022-07, P≤1mW; λ = 670nm
Measurement range		25mm, 18mm < x < 43mm
Start of measurement range		Starting from armored glass window 18mm
Center of measurement range		Starting from armored glass window 30mm
End of measurement range		Starting from armored glass window 43mm
Linearity		< ±25µm < ±0,10% FSO
Reproducibility		2,5µm
Temperature stability		±0,015% FSO / K
Measuring rate		1kHz
Permissible ambient light		20000 lx
Spot size		Start of measurement range 200 x 260µm Center of measurement range 55 x 60µm End of measurement range 255 x 330µm
Interface		RS422 / 16 Bit
START input, function		„low“ active, 0V starts measurement
Original device type		ILD1220-25 (Micro-Epsilon)
Supply voltage, Ue		+24VDC +/-10%
Power consumption		< 2W
Analog current outputs, operating range		4 - 20mA (4mA = 18mm, 20mA = 43mm)
Analog output, fault messages		3 mA: Outside the measuring range
Housing		Aluminum
Enclosure rating		IP65
Ambient working temperature range, T _{amb}		0°C up to +50°C
Storage temperature range		-20°C up to +70°C
Connection cable		Length 3, shielded
ATEX related markings		<div style="display: flex; justify-content: space-between;"> <div style="width: 30%;"> <p>CE 1258 Typ: LTG-BCC-1CA-TF Gas: Ⓜ II 2(1)G Ex db [op is Ga] IIC T4 Gb ATEX: IECEX: Tamb: Manufacturing date:</p> </div> <div style="width: 35%;"> <p>Manufacturer with Address Electrical data according to table Dust: Ⓜ II 2(1)D Ex tb [op is Da] IIIC T135°C Db SEV 23 ATEX 0648 X IECEX SEV 23.0001X 0°C up to +50°C Number 5 to 8 of the Serial Number (Year / CW)</p> </div> </div>
Wiring and Connection		<div style="display: flex;"> <div style="width: 30%;"> <p>red +24VDC +/-10%</p> <p>blue 0V (GND)</p> <p>white 4 - 20mA / 12 Bit</p> <p>black START input</p> <p>green RX+</p> <p>yellow RX-</p> <p>grey TX+</p> <p>pink TX-</p> </div> <div style="width: 65%;">  </div> </div>

LTG-BCC-1CA-TF_e1/2026-03-26/MP

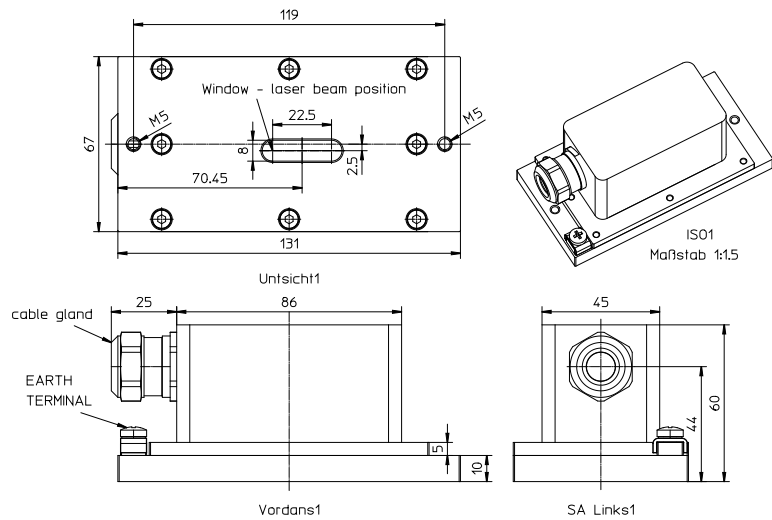
Dimensions in mm



Operating Manual / EC/EU-declaration of conformity

Intended Use

The distance sensor is used for the contactless measurement of distances. It must be planned, installed and operated accordingly.

General assembly instructions

The electrical connections must be exactly as shown in the connection diagram. The sensor cables must not be laid parallel to high-current and/or high-voltage cables. The maximum limit values must not be exceeded.

Installation prescriptions for Ex hazardous locations

It is necessary to take into consideration all the valid international and national rules and regulations (DIN EN 60079-14:2014-10). Do not exceed the maximum ratings. The electrical connections must be exactly as shown in the wiring diagram. The local equipotential bonding connection is corrosion-resistant and durable to connect. The protective earth (PE) has to be connected solid with the housing. The cable shield should be connected to the protection earth (PE). Do not connect the cable shield to PE if it is not identical to the PE connected to the housing. The cable has to be installed and protected against damages. Install cables with termination fittings or put in cable tray systems in a manner to avoid tensile stress at the termination fittings. Adequate strain relief must be provided. The end of the cable must either be installed within a certificated Ex housing or must be installed outside of any Ex area. **The housing must be installed in such a way that the risk of propagation of brush discharges when used in an explosive dust atmosphere can be avoided.** Type LTG-BCC-1CA-TF: Allowed to be installed and operated within Ex zones 1 and 21. The limited optical radiation of the laser can operate into hazardous locations zone 0 and 20.

Safety Fuse

To ensure the safety of the sensor in the event of a fault, the sensor must be connected to an external fuse of 24V and 150mA. The user is responsible for the correct installation and use of the sensor. In case of incorrect handling of the sensor, Matrix Elektronik AG rejects any liability.

Function

The device uses the principle of optical triangulation, that is, a visible, modulated point of light is projected onto the target surface. The diffuse part of the reflection of this point of light is displayed depending on distance on a position-resolving element (CMOS) by a receiver optic which is arranged to the optical axis of the laser beam in a defined angle. A signal processor in the sensor calculates the distance of the point of light on the measuring object to the sensor by means of the output signal of the CMOS elements. The distance value is linearized and output by means of the analog or RS422 interface.

Analog output

Output current 4... 20mA:	Measure object
Output current 3mA:	No object in the measuring range

Serial data output

The serial data output RS422 provides the distance of the measurement object from the sensor in digital form.

START input

The measuring process is started by applying 0VDC to the START input. If there is + 24V or "open" at the start input, the measurement is ended. We recommend planning this "START input" in the application. Use this input to select or deselect the laser. As a result, stray laser beams can be avoided when measurement is not required and the lifespan of the laser can be extended accordingly.

Maintenance

The sensor is maintenance-free. If it becomes dirty, the light passage must be cleaned carefully. No aggressive cleaning agents may be used. Repairs may only be carried out by the manufacturer.

Safety instructions for class 2 laser equipment

The standard „Safety of laser devices“ EN 60825-1 must be followed during assembly, commissioning and use. Do not look into the laser beam!

General safety instructions

The sensor is to be used in such a way that in the event of malfunction or total failure of the sensor, no people endangered or machinery damaged. The relevant EU and national regulations and guidelines must be observed during assembly, operation and maintenance. The sensors comply with the following standards: EN 61000-6-2, EN 61000-6-3, EN 61326-1.

General disposal

We reserve the right to make technical changes. The sensors are built to be as environmentally friendly as possible. Irreparable or no longer used devices must be disposed of in accordance with the applicable regulations.

EU-Declaration of Conformity

The product meets the requirements of the following standards and directives: EN IEC 60079-0:2018, EN 60079-1:2014, EN 60079-28:2015, EN 60079-31:2014, EN 60825-1:2006, EN 60825-2:2004, EN 60529, EN 61000-4-2 to EN 61000-4-6, EN 61000-6-1/-2, EN 61000-6-4, ATEX directive 2014/34/EU, Machine directive 2006/42/EC, EMC directive 2014/30/EU, RoHS directive 2011/65/EU

ATEX/IECEx-Designation:

Gas: II 2(1)G Ex db [op is Ga] IIC T4 Gb
 Dust: II 2(1)D Ex tb [op is Da] IIIC T135°C Db
 ATEX EU-type examination certificate No.: SEV 23 ATEX 0648 X
 IECEx CoC No.: IECEx SEV 23.0001X
 Ex CB IECEx: Eurofins Electric & Electronic Product Testing AG, Luppmen-

strasse 3, CH-8320 Fehraltorf, CE 1258

ATEX certification of quality management system, type production of Ex devices, in accordance to the directive 2014/34/EU:

Certification No.: SEV 21 ATEX 4580, QAR No.: CH/SEV/QAR21.0009, CB: Eurofins Electric & Electronic Product Testing AG, Luppmenstrasse 3, CH-8320 Fehraltorf CE 1258.

Pablo Ledergerber, Matrix Elektronik AG, is authorized to generation of documentation.

The conformity of the devices with all used standards and directives and the EC-type examination certificate and the observation of the Quality Management System ISO 9001:2015, declares:

Ehrendingen, 26.3.2026

Pablo Ledergerber, Matrix Elektronik AG

LTG-BCC-1CA-TF_e1/2026-03-26/MP

Trippkemper-Matrix GmbH
 Meegerner Str. 43, D-51491 Overath
 Tel.: +49 2206 9566-0, Fax -19
 info@trippkemper-matrix.de

Matrix Elektronik AG (Manufacturer)
 Kirchweg 24, CH-5420 Ehrendingen
 Tel.: +41 56 20400-20, Fax -29
 info@matrix-elektronik.com