

Operating manual: LDH-AAA-FCB-TF-S336 Laser distance sensor



II 2(1)G

IECEx BVS 14.0108X



Ex db [op is Ga] IIA T3 Gb

- ATEX and IECEx certified
- For use in Ex Zones (0), 1, 2
- Measurement range analog output: 0.05m to 30m
- Measurement range digital output: 0.05m to 30m
- High measurement accuracy
- Analog output signal 4mA to 20mA and serial data interface RS-485
- Easy alignment through visible red light laser
- Stainless steel 1.4404 housing
- With built-in heating element to prevent lens fogging

Type	LDH-AAA-FCB-TF-S336	
Technical Data		
Gas Ex protection designation	II 2(1)G Ex db [op is Ga] IIA T3 Gb	
For use in Ex Zones	Zones (0), 1, 2	
Measurement methods	Time-of-flight measuring	
Light Source	Laser Class 2, in accordance with EN 60825-1	
Maximum optical radiant intensity	<=1mW, wave length: 650nm	
Response time	minimum 0.1s, maximum 4.5s	
Pollution degree	4	
Utilization category according to EN 60947-5-1	D3A42AP1	
Supply voltage, Ue	+24VDC ±10%	
Absolute maximum supply voltage, Um	30VDC	
Current consumption	200mA	
Maximum power dissipation	6W	
Typical measurement tolerance	up to 10m: +-1mm, applies for 100% target reflectivity, in low-light ambient, T _{amb} : 25°C	
Maximum measurement tolerance	up to 10m: +-2mm, applies for 10% to 500% target reflectivity, in strong light ambient	
Distance dependent increase of measurement tolerance	<=0.15mm/m	
Analog current output, type	PNP, 4mA to 20mA, short circuit protected	
Analog current outputs, operating range	0.05m to 30m (0.05m = 4mA, 30m = 20mA)	
Analog current output, error indication	3.5mA: Measurement invalid 20.5mA: Object out of measurement range	
Analog current output, resolution	1mm = 0,0005mA	
Analog current output, load range	500R <= R _L <= 1000R	
Serial interface, type	RS 485, Format: 9600 baud, 8 data bits, 1 stop bit, Parity none, Handshaking none	
Serial interface, range	0.05m to 30m	
Serial interface, resolution	1mm	
Power up delay time	500ms	
Housing	M42, Material: Stainless steel 1.4404	
Enclosure rating	IP67	
Ambient working temperature range, T _{amb}	-10°C up to 35°C ¹ / -10°C up to +50°C ²	
Storage temperature range	-20°C up to +70°C	
Relative humidity	15% ... 80%	
Laser lifetime	Appr. 30'000h, typically, at a housing temperature of +20°C. During continuous operation.	
Connection cable	Length: 5m, PUR jacket, 6+PE x 0.5mm ² , shielded, non-halogen, leads numbering marked, good chemical resistance, drag chain suitable	
Options	• Cable length: Up to 100m, upon request	
Accessories	Included	Optional
	• 2x nuts M42	
Notes	¹ For a longer life time of the laser diode, the housing temperature of 35°C must not be exceeded. ² For housing temperature larger than 35°C use the sensor in pulse mode. See please document "Datasheet supplement"	
EX related markings	CE 1258 Typ: LDH-AAA-FCB-TF-S336 Gas: II 2(1)G Ex db [op is Ga] IIA T3 Gb ATEX: IECEx: Tamb: Manufacturing date:	Manufacturer with Address Electrical data according table BVS 10 ATEX E 130 X IECEx BVS 14.0108X -10°C up to 35°C Number 5 to 8 of the Serial Number (Year / CW)
Electrical connection		
Wire number	Function	
1	+24VDC ±10%	
2	0V	
3	NC	
4	Current output: PNP, 4mA to 20mA	
5	RS 485 - Y	
6	RS 485 - Z	
yellow-green	PE	
white	Cable shield	

LDH-AAA-FCB-TF-S336_e1/2022-04-28/PDL

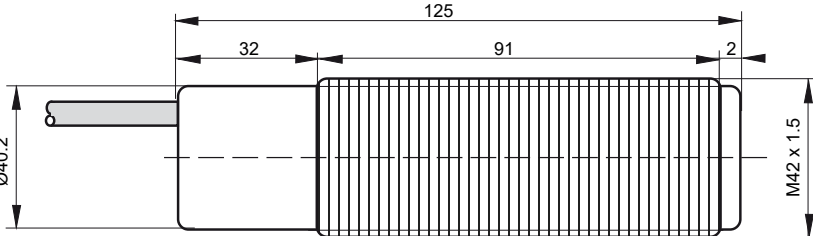
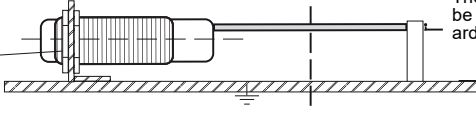
Dimensions	
Safe equipotential bonding for Ex devices	 <p>Ensure local equipotential bonding by means of a corrosion-resistant PE connection.</p> <p>The end of the cable must be connected outside the hazardous locations.</p> <p>The cable shield is to connect to PE in a wide area.</p>

Operating Manual / EC-/EU-declaration of conformity

Intended Use

The distance sensor type LDH-AAA-FCB-TF-S336 is designed to measure distances within potentially explosive atmospheres. It must be installed and operated in accordance to this operating manual.

Installation prescriptions for Ex hazardous locations

It is necessary to take into consideration the valid international and national rules and regulations (EN 60079-14). The local potential equalization must be connected with the PA-connector using a reliable and noncorrosive connection. The PE/PA connector is permanently attached to the enclosure. The absolute maximum supply voltage $U_m = 30VDC$ must not be exceeded. No external parts are allowed for focusing or reshaping of the emitted laser beam, except for original parts. The cable must be protected against damaging. The end of the cable must either be installed within a certificated Ex housing or must be installed outside of any Ex area.

Type LDH-AAA-FCB-TF-S336: Allowed to be installed and operated within Ex zones 1 and 2. The limited optical radiation can operate into hazardous locations zones 0.

General Installation Prescriptions

Do not exceed the maximum ratings. The electrical connections must be exactly as shown in the connection diagram. The cable shield must be connected short. The cable shield must be connected to the protection earth, large-surfaced. Connection cables must not be installed parallel to high voltage cables. The cable shield is to connect at PE.

Function

The sensor uses the time of flight measurement principle. The travel time of an emitted pulse of light is measured, whereby the pulse travels from the sensor to the measured object and back. The relation between distance and travel time is given by the speed of light. This measurement principle requires the measured object to reflect a part of the incident radiation towards the source. The acquired measurement result is available at the analog current output and the RS 485 interface in parallel. As soon as the sensor is connected to 24V, the sensor starts to emit light with a clocking of ON:15s / OFF:45s. With this set clocking, the life of the laser diode is extended up to approx. 120000 hours.

Lens heater

The sensors of the LDx-xxx-xxB-xx type have a built-in heater on the lens. This avoids, due to temperature changes and high humidity, the fogging on the glass window. The heater regulates itself automatically and at a temperature below 25°C it switches on.

Analog current output

Output current 4mA to 20mA:	Valid measurement result
Output current 3.5mA:	No valid measurement could be achieved
Output current 20.5mA:	No object could be detected within range

Serial interface

The RS 485 serial interface presents the measurement results, in the range from 0.05m to 30m, in a digital format. The interface is configured to 9600, 8 data bits, 1 stop bit, no parity and no handshaking. Each result is presented as human readable ASCII string containing the measured distance in millimeters followed by carriage return and line feed characters (CR+LF).

Maintenance and durability

For housing temperatures higher than 35°C, please refer to the document "Data sheets supplements. The sensor is maintenance-free. The measurement window must be cleaned carefully if soiled. Never use aggressive cleaning agents. Equipment must only be repaired or serviced by the manufacturer. The laser flashes in continuous measuring mode.

Safety regulations for Laser devices class 2

 Throughout the installation, the going into operation and the application, it is necessary to take into consideration the valid rule EN 60825-1. Do not stare into the beam!

General safety informations

The equipment is not used for the prevention of accidents. In worst case of disturbance, the output can show any state. The mounting, wiring, application and maintenance must be realized in accordance with the relevant rules and prescriptions. It is necessary to take into consideration the relevant international and national regulations.

General notes, disposal

We reserve the right to modify our equipment. Our equipment is designed such way, that it has the least possible adverse effect on the environment. It neither emit or contain any damaging or siliconized substances and use a minimum of energy and resources. No longer usable or irreparable units must be disposed of in accordance with the local waste disposal regulations.

EU-Declaration of Conformity

The product meets the requirements of the following standards and directives: IEC 60079-0:2017, EN IEC 60079-0:2018, IEC/EN 60079-1:2014, IEC/EN 60079-28:2015, EN 60529:2014, EN 60950-1:2006, EN 61000-4-2 to EN 61000-4-6, EN 61000-6-1/-2, EN 61000-6-4, ATEX directive 2014/34/EU, Machine directive 2006/42/EC, EMC directive 2014/30/EU, RoHS directive 2011/65/EU

ATEX/IECEx-Designation:

Gas: II 2(1)G Ex db [op is Ga] IIA T3 Gb
 ATEX EU-type examination certificate No.: BVS 10 ATEX E 130 X
 IECEx CoC No.: BVS 14.0108X
 Ex CB IECEx: DEKRA Testing and Certification GmbH, Carl-Beyling-Haus, Dinendahlstrasse 9, D-44809 Bochum.

ATEX certification of quality management system, type production of Ex devices, in accordance to the directive 2014/34/EU:

Certification No.: SEV 21 ATEX 4580, QAR No.: CH/SEV/QAR21.0009/00, CB: Eurofins Electric & Electronic Product Testing AG, Luppenstrasse 3, CH-8320 Fehraltorf. CE 1258 Ident. Number: 1258

Pablo Ledergerber, Matrix Elektronik AG, is authorized to generation of documentation.

The conformity of the devices with all used standards and directives and the EC-type examination certificate and the observation of the Quality Management System ISO 9001:2015, declares:

Ehrendingen, 28.4.2022



Pablo Ledergerber, Matrix Elektronik AG

LDH-AAA-FCB-TF-S336_e1/2022-04-28/PDL

Tippkemper-Matrix GmbH
 Meegerer Str. 43, D-51491 Overath
 Tel.: +49 2206 9566-0 Fax -19
 info@tippkemper-matrix.de

Matrix Elektronik AG (Manufacturer)
 Kirchweg 24, CH-5420 Ehrendingen
 Tel.: +41 56 20400-20 Fax -29
 info@matrix-elektronik.com