

Operating manual: LDN-301-DI4-OP-S331 Laser distance sensor



II 3G Ex nA op is IIB T4 Gc
II 3D Ex tc op is IIIB T135°C Dc

- Measurement range analog output: 50mm to 400mm
- Measurement range digital output: 0.05m to 30m
- High measurement accuracy
- Analog output signal 4mA to 20mA and serial data interface RS-485
- Easy alignment through visible red light laser
- Stainless steel 1.4404 housing

Technical Data	Type	LDN-301-DI4-OP-S331
Gas Ex protection designation		II 3G Ex nA op is IIB T4 Gc
Dust Ex protection designation		II 3D Ex tc op is IIIB T135°C Dc
For use in Ex Zones		Zones 2, 22
Measurement methods		Time-of-flight measuring
Light Source		Laser Class 2, in accordance with EN 60825-1
Maximum optical radiant intensity		<=1mW, wave length: 620nm - 690nm
Response time		minimum 0.25s, maximum 2.5s
Pollution degree		4
Utilization category according to EN 60947-5-1		D3A42AP1
Supply voltage, Ue		24VDC
Absolute maximum supply voltage, Um		30VDC
Current consumption		70mA
Maximum power dissipation		2.4W
Typical measurement tolerance		up to 10m: +-1mm, applies for 100% target reflectivity, in low-light ambient, T _{amb} : 25°C
Maximum measurement tolerance		up to 10m: +-2mm, applies for 10% to 500% target reflectivity, in strong light ambient
Distance dependent increase of measurement tolerance		<=0.15mm/m
Analog current output, type		PNP, 4mA to 20mA, short circuit protected
Analog current outputs, operating range		50mm to 400mm (50mm = 4mA, 400mm = 20mA)
Analog current output, error indication		3.5mA: Measurement invalid 20.5mA: Object out of measurement range
Analog current output, resolution		1mm = 0,053mA
Analog current output, load range		500R <= R _L <= 1000R
Serial interface, type		RS 485, Format: 9600 baud, 8 data bits, 1 stop bit, Parity none, Handshaking none
Serial interface, range		0.05m to 30m
Serial interface, resolution		1mm
Input type		START Input, PNP compatible
Input function		"H" +24VDC: Starts measurement, "L" 0V: Stops measurement
Power up delay time		500ms
Housing		M42, Material: Stainless steel 1.4404
Enclosure rating		IP67
Ambient working temperature range, T _{amb}		-10°C up to +35°C ¹ / -10°C up to +50°C ²
Storage temperature range		-20°C up to +70°C
Relative humidity		15% ... 80%
Laser lifetime		Appr. 30'000h, typically, at a housing temperature of +20°C. During continuous operation. Urgent recommendation: Apply 0V to the START-input, when no measurement is necessary
Connection cable		7 x AWG24 with PTFE insulation, outer jacket from FEP, shielded, according to USFXXIII Class VI, wires colored, length: 5m, cable diameter: 5.4mm, bending radius = 30mm, bending radius moving = 60mm
Options		• Cable length: Up to 100m, upon request
Accessories		Included
		• 2x nuts M42
		Optional
Notes		¹ For a longer life time of the laser diode, the housing temperature of +35°C must not be exceeded. ² For housing temperature larger than +35°C use the sensor in pulse mode. See please document "Datasheet supplement"
EX related markings		CE 0158 Typ: LDN-301-DI4-OP-S331 Gas: Ⓜ II 3G Ex nA op is IIB T4 Gc ATEX: Tamb: Manufacturing date:
		Manufacturer with Address Electrical data according table Dust: Ⓜ II 3D Ex tc op is IIIB T135°C Dc Declared by manufacturer according to 2014/34/EU -10°C up to +35°C Number 5 to 8 of the Serial Number (Year / CW)

LDN-301-DI4-OP-S331_e1/2021-09-01/MP

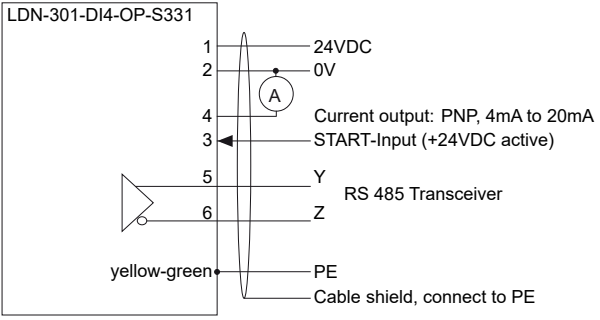
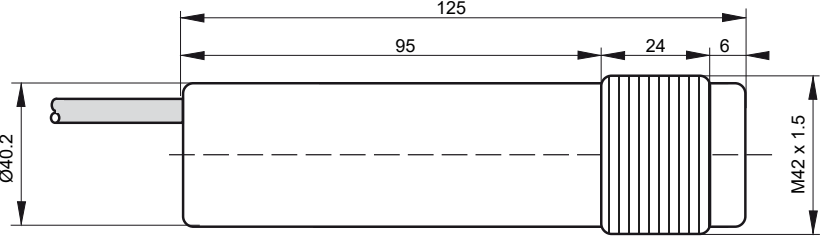
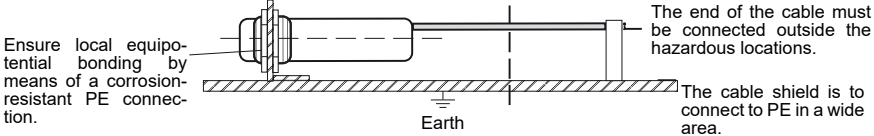
<p>Electrical connection</p> <table border="1"> <thead> <tr> <th>Wire number</th> <th>Function</th> </tr> </thead> <tbody> <tr> <td>brown</td> <td>24VDC</td> </tr> <tr> <td>white</td> <td>0V</td> </tr> <tr> <td>pink</td> <td>START-Input (+24VDC active)</td> </tr> <tr> <td>grey</td> <td>Current output: PNP, 4mA to 20mA</td> </tr> <tr> <td>yellow</td> <td>RS 485 - Y</td> </tr> <tr> <td>green</td> <td>RS 485 - Z</td> </tr> <tr> <td>yellow-green</td> <td>PE</td> </tr> <tr> <td>white, with designation</td> <td>Cable shield</td> </tr> </tbody> </table>	Wire number	Function	brown	24VDC	white	0V	pink	START-Input (+24VDC active)	grey	Current output: PNP, 4mA to 20mA	yellow	RS 485 - Y	green	RS 485 - Z	yellow-green	PE	white, with designation	Cable shield	
Wire number	Function																		
brown	24VDC																		
white	0V																		
pink	START-Input (+24VDC active)																		
grey	Current output: PNP, 4mA to 20mA																		
yellow	RS 485 - Y																		
green	RS 485 - Z																		
yellow-green	PE																		
white, with designation	Cable shield																		
<p>Dimensions</p>																			
<p>Safe equipotential bonding for Ex devices</p>																			

Operating Manual / EC-/EU-declaration of conformity

Intended Use

The distance sensor type LDN-301-DI4-OP-S331 is designed to measure distances within potentially explosive atmospheres. It must be installed and operated in accordance to this operating manual.

Installation prescriptions for Ex hazardous locations

It is necessary to take into consideration the valid international and national rules and regulations (EN 60079-14). The local potential equalization must be connected with the PA-connector using a reliable and noncorrosive connection. The PE/PA connector is permanently attached to the enclosure. The absolute maximum supply voltage $U_m = 30VDC$ must not be exceeded. No external parts are allowed for focusing or reshaping of the emitted laser beam, except for original parts. The cable must be protected against damaging. The end of the cable must either be installed within a certificated Ex housing or must be installed outside of any Ex area.

Type LDN-301-DI4-OP-S331: Allowed to be installed and operated within Ex zones 2 and 22.

General Installation Prescriptions

Do not exceed the maximum ratings. The electrical connections must be exactly as shown in the connection diagram. The cable shield must be connected short. The cable shield must be connected to the protection earth, large-surfaced. Connection cables must not be installed parallel to high voltage cables. The cable shield is to connect at PE.

Function

The sensor uses the time of flight measurement principle. The travel time of an emitted pulse of light is measured, whereby the pulse travels from the sensor to the measured object and back. The relation between distance and travel time is given by the speed of light. This measurement principle requires the measured object to reflect a part of the incident radiation towards the source. The acquired measurement result is available at the analog current output and the RS 485 interface in parallel.

Analog current output

Output current 4mA to 20mA:	Valid measurement result
Output current 3.5mA:	No valid measurement could be achieved
Output current 20.5mA:	No object could be detected within range

Serial interface

The RS 485 serial interface presents the measurement results, in the range from 0.05m to 30m, in a digital format. The interface is configured to 9600, 8 data bits, 1 stop bit, no parity and no handshaking. Each result is presented as human readable ASCII string containing the measured distance in millimeters followed by carriage return and line feed characters (CR+LF).

START input

The measurement process is started by applying +24VDC at the START input. The device will stop to perform measurements if the START input is connected to 0V. For a longer lifetime of the laser, activate the sensor only when measurement is necessary.

Maintenance and durability

Urgent recommendation for longer lifetime of the laser: When no measurement is being made, disable the laser, by switching the START-Input to 0V. For housing temperatures higher than 35°C, please refer to the document "Data sheets supplements. The sensor is maintenance-free. The measurement window must be cleaned carefully if soiled. Never use aggressive cleaning agents. Equipment must only be repaired or serviced by the manufacturer. The laser flashes in continuous measuring mode.

Safety regulations for Laser devices class 2

Throughout the installation, the going into operation and the application, it is necessary to take into consideration the valid rule EN 60825-1. Do not stare into the beam!

General safety informations

The equipment is not used for the prevention of accidents. In worst case of disturbance, the output can show any state. The mounting, wiring, application and maintenance must be realized in accordance with the relevant rules and prescriptions. It is necessary to take into consideration the relevant international and national regulations.

General notes, disposal

We reserve the right to modify our equipment. Our equipment is designed such way, that it has the least possible adverse effect on the environment. It neither emit or contain any damaging or siliconized substances and use a minimum of energy and resources. No longer usable or irreparable units must be disposed of in accordance with the local waste disposal regulations.

EU-Declaration of Conformity

The product meets the requirements of the following standards and directives: EN/IEC 60079-0:2018, IEC/EN 60079-15:2010, IEC/EN 60079-28:2015, EN 60079-31:2014, EN 60529:2014, EN 60950-1:2006, EN 61000-4-2 to EN 61000-4-6, EN 61000-6-1/-2, EN 61000-6-4, ATEX directive 2014/34/EU, Machine directive 2006/42/EC, EMC directive 2014/30/EU, RoHS directive 2011/65/EU

ATEX/IECEx-Designation:

Gas: II 3G Ex nA op is IIB T4 Gc
Dust: II 3D Ex tc op is IIIB T135°C Dc

ATEX declaration by manufacturer according to 2014/34/EU

ATEX certification of quality management system, type production of Ex devices, in accordance to the directive 2014/34/EU:

Certification No.: BVS 18 ATEX ZQS / E118, QAR No.: DE/B-VS/QAR13.0004/06, CB: DEKRA Testing and Certification GmbH, Carl-Beyling-Haus, Dinendahlstrasse 9, D-44809 Bochum. Ident. Number: 0158 Pablo Ledergerber, Matrix Elektronik AG, is authorized to generation of documentation.

The conformity of the devices with all used standards and directives and the EC-type examination certificate and the observation of the Quality Management System ISO 9001:2015, declares:

Ehrendingen, 1.9.2021



Pablo Ledergerber, Matrix Elektronik AG

LDN-301-DI4-OP-S331_e1/2021-09-01/MP

Tippkemper-Matrix GmbH
Meegener Str. 43, D-51491 Overath
Tel.: +49 2206 9566-0, Fax -19
info@tippkemper-matrix.de

Matrix Elektronik AG (Manufacturer)
Kirchweg 24, CH-5420 Ehrendingen
Tel.: +41 56 20400-20, Fax -29
info@matrix-elektronik.com